

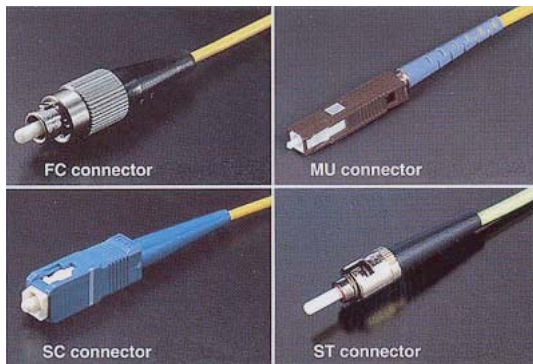

PM/SM/MM Fiber Cable Assembly



www.princetel.com

Princetel, Inc.
4 Princess Rd Ste 209
Lawrenceville, NJ 08648
609.895.9890
fax 609.895.9552
info@princetel.com



PM/SM/MM Fiber Cable Assembly

Like singlemode fiber, polarization maintaining (PM) fiber supports single spatial mode for the designed wavelength. Unlike singlemode fiber though, PM fiber maintains a linear polarization state when linearly polarized light is launched along its fast or slow axis.

The two axes are defined based on the speed light propagates along them. The speed difference is caused by the stress applying members. In case of the popular PANDA fiber, the slow axis is essentially the line linking the two stress members.

In general, PM fibers can not be used as polarizers. However, when the optical wavelength falls between the cut-off wavelength of the fast and the slow axes, some polarizing effect can be observed.

For more in depth discussion on PM fiber go to our "Tutorial" page for "PM fiber termination/connectorization".

Besides PM fiber assemblies, we also offer multiple fiber assemblies for singlemode and multimode fibers.

PM Fiber Assemblies

Extinction ratio (ER)	>25 dB
Key alignment accuracy	+/- 3 degrees
Return loss (UPC)	>45 dB
Return loss (APC)	>60 dB
Operating temperature	5 to 40 C
Storage temperature	0 to 65 C

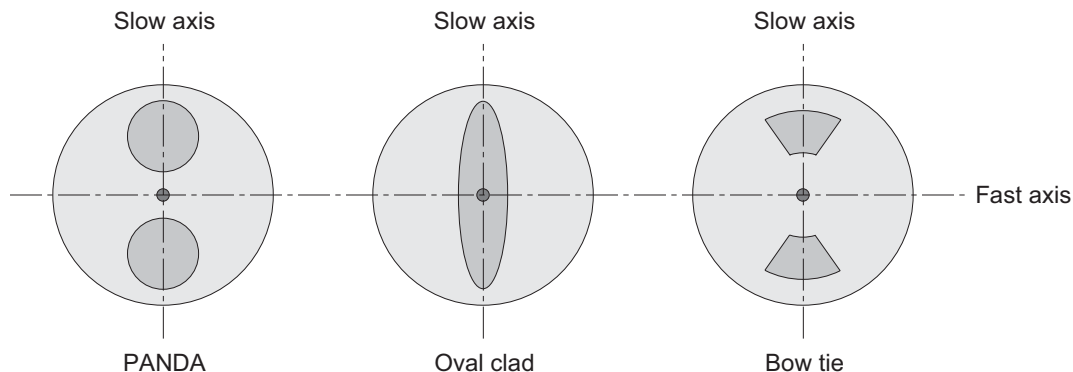



PM/SM/MM Fiber Cable Assembly

Multiple Fiber Assemblies



A=2 fiber
B=4 fiber

Fiber
28=SMF28
13=SM13 PANDA
15=SM15 PANDA
56=FS-SN5624 (980 nm)
42=FS-SN4224 (850 nm)
32=FS-SN3224 (635 nm)
50=50/125
62=62.5/125
10=100/125

Length
001=0.1 m
010=1 m
100=10 m

Jacket
B=Bare fiber
T=Tight buffer
L=Loose tube

Connector
FC=FC
FA=FCAPC
SC=SC
SA=SCAPC
LC=LC
GF=Glass twin 0 deg
GA=Glass twin 8 deg
CF=Ceramic quad 0 deg
CA=Ceramic quad 8 deg

4-fiber ceramic ferrules

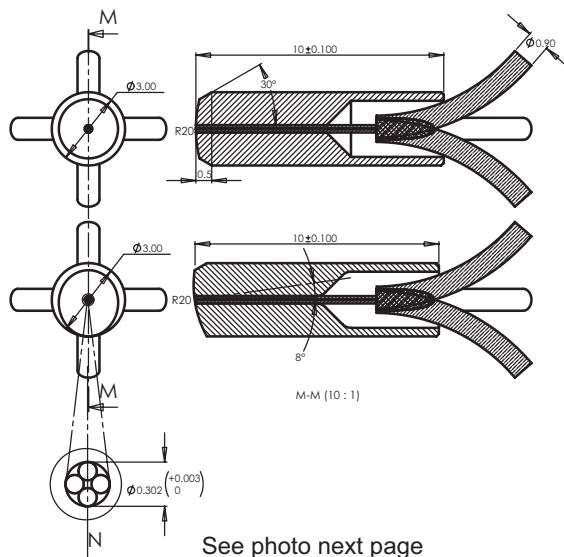

2-fiber glass ferrules

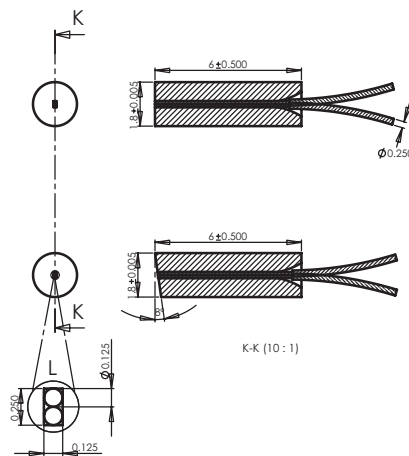

UNIT: mm



PM/SM/MM Fiber Cable Assembly

Sample PANDA fiber specifications

Description	Unit	Specifications	
Manufacturer	-	Fujikura LTD	
Model number	-	SM.13-P-7/125-UV/UV-400	SM.15-P-8/125-UV/UV-400
Fiber type	-	Polarization maintaining	
Structure	-	PANDA (Stress applying type)	
Wavelength	um	1.3	1.55
Fiber diameter	um	125 +/-3.0	125 +/-3.0
Mode field diameter	um	9.5 +/-1.0	10.5 +/-1.0
Core-to-cladding error	um	</= 1.0	</= 1.0
Jacket type	-	Dual UV curable acrylic	
Jacket diameter	um	400 +/- 20	400 +/- 20
Cut off wavelength	um	1.10 to 1.29	1.29 to 1.45
Attenuation	dB/km	</= 1.00	</= 0.50
Group beat length	mm	</= 4.0	</= 5.0
Extinction ratio	dB	>/=25	>/=25
Proof test level	%	>/= 1.0	>/= 1.0

Image of a polished PANDA fiber

PM fibers are notorious in generating false readings during stress member alignment. Princetel's proprietary imaging technology produces superb pictures of the fiber facet. No misalignment will escape our trained eyes.

This photo was taken under a special designed microscope with a magnification of 280.

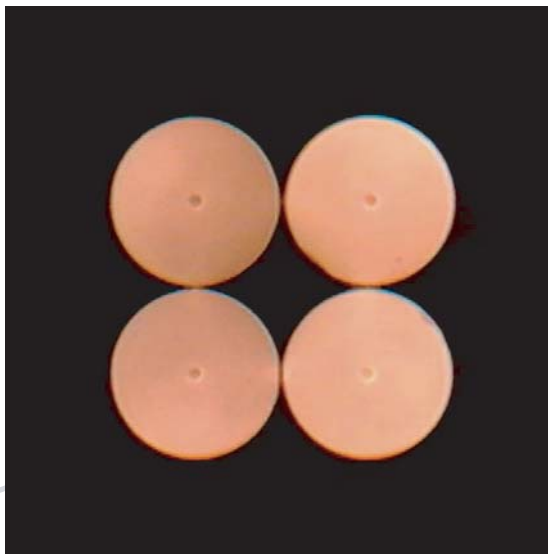
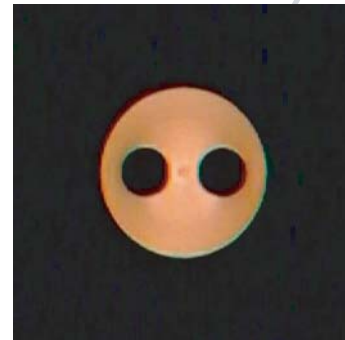

Image of 4 fibers in a ferrule

Four singlemode fibers are placed in a single ferrule. UPC polish reveals their cores and claddings. This fiber assembly is ideal for four-channel fiber devices such as filters, isolators, swithes, attenuators, and circulators.

This photo was taken under a special designed microscope with a magnification of 280.